

**FiberLight miniature UV/vis light source**  
for mobile spectroscopy and online process control

# Fiberlight for innovative solutions

FiberLight is a miniature UV-Vis light source with a continuous spectrum covering the whole range from vacuum UV to near Infrared. This light source was developed in response to customer requests for a small UV-Light source with negligible heat generation.

The features of this light source open the way for new solutions in small spectroscopy equipment and UV optics.

## Features are

- small size
- low power consumption (6 W)
- low heat generation
- easy coupling to optical fibers, measuring cells and capillaries
- lifetime up to 3 years
- robust mode of operation

## Current applications

- Modular Miniature UV-Spectrometers
- Handheld equipment for outdoor spectroscopy
- for analysis in waters and waste water
- for oil-in-water analysis
- for deep sea water analysis
- Sealed equipment for process control
- Measurements in the vacuum UV spectral range
- Measurements under hyper- and zero-gravity

## Miniature Deuterium Lamp

FiberLight incorporates a miniature Deuterium Lamp – an electrode-less high frequency excited gas discharge lamp.

The Deuterium Lamp features small size, 3 Watt power consumption, and negligible heat generation.

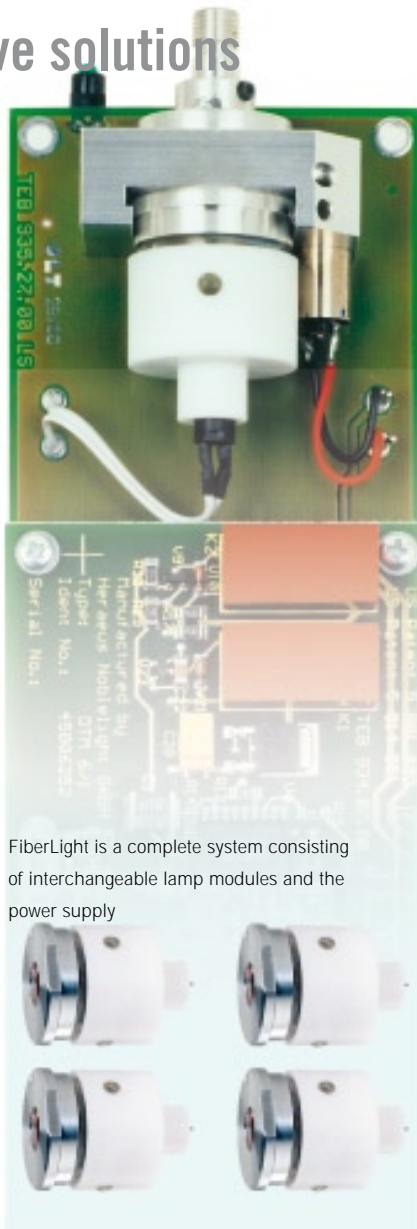

FiberLight is a complete system consisting of interchangeable lamp modules and the power supply

FiberLight is a complete UV-Vis light source with a shine-through design deuterium lamp, a 0.25 Watt tungsten lamp, shutter, optical system and SMA 905 connector. All elements are mounted on a printed circuit board driven by an external 12 Vdc/600 mA power supply. Both lamps and the shutter can be controlled by a TTL signal.

## FiberLight Lamp Modules

A lamp module consists of the Deuterium lamp, the tungsten lamp and the prealigned mounting ring.

There are 4 modules available with different spectral and optical features. The lamp modules are interchangeable:

1. **DTM 6/10** UV-Vis Lamp Module, spectral range 200 – 1100 nm, aperture 1.0 mm, for fibers of 400 – 600  $\mu\text{m}$  diameter
2. **DTM 6/50** UV-Vis Lamp Module, spectral range 200 – 1100 nm, aperture 0.5 mm, for fibers of 200 – 600  $\mu\text{m}$  diameter
3. **DTM 6/10S** UV-Vis Lamp Module, spectral range 185 – 1100 nm, aperture 1.0 mm, for fibers of 400 – 600  $\mu\text{m}$  diameter
4. **DTM 6/50S** UV-Vis Lamp Module, spectral range 185 – 1100 nm, aperture 0.5 mm, for fibers of 200 – 600  $\mu\text{m}$  diameter

▲ 4 different lamp modules are available: Deuterium lamps with 1.0 mm or 0.5 mm aperture Standard Quartz as well as Suprasil Deuterium lamps with spectra ranging from 200 nm to 1100 nm and 160 nm to 1100 nm respectively. The fiber limits the spectral output to 185 nm at short UV wavelength.

▼ Spectral Distribution of FiberLight – measured with optical fiber 400  $\mu\text{m}$ .

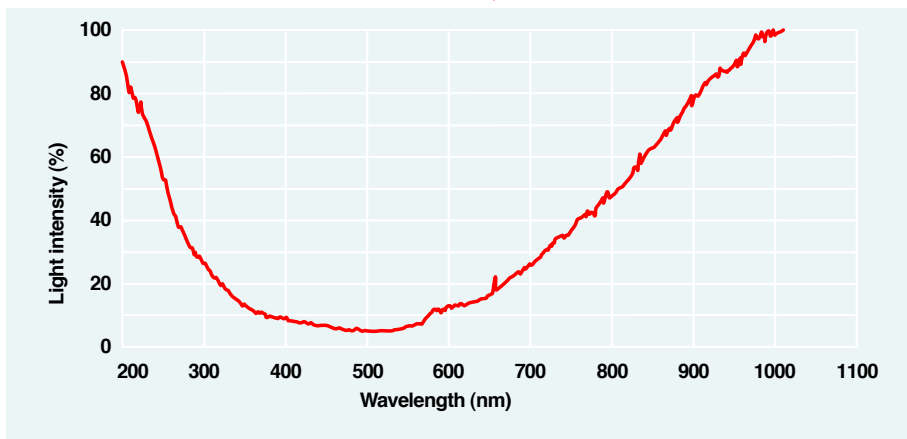

▼ Spectral Distribution (Vacuum UV range) – measured under vacuum without optical fiber.

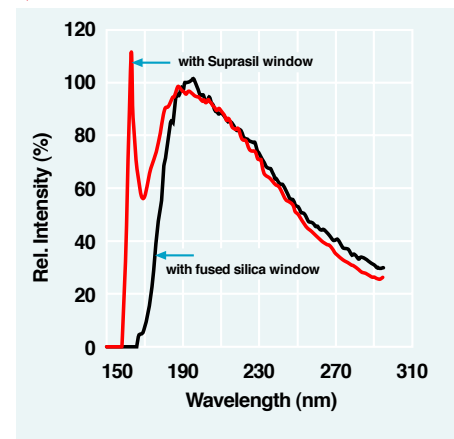

## The high frequency excited

### Deuterium lamp

The high frequency excitation provides immediate ignition of the Deuterium lamp. The lamp can be switched on and off at any time and can be operated in cycles.

### Life

The continuous operating life of the FiberLight Deuterium lamp is more than 1000 hours. As the lamp can be switched on and off on demand or operated in cycles the lifetime can be extended considerably. The number of ignitions affect the operating life only insignificantly.

For example in nitrate measurements in waste water FiberLight is switched on every 30 seconds for just 1 second. The measurement is started after a delay of 0.5 seconds. After this delay FiberLight has a very good pulse-to-pulse-stability of approx. 0.1 % in the UV spectral range.

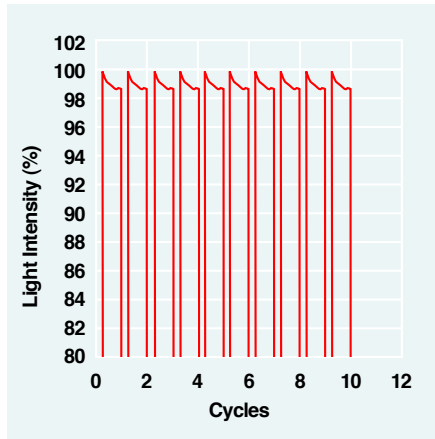

▲ Cyclic Operation measured at 230 nm, measuring time: 15 sec; off = 75 sec.

▼ Lamp Life Characteristic FiberLight DTM 6/10 – measured at 250 nm.

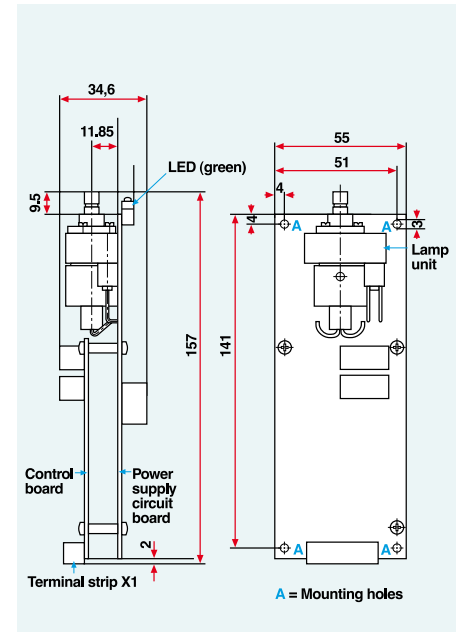
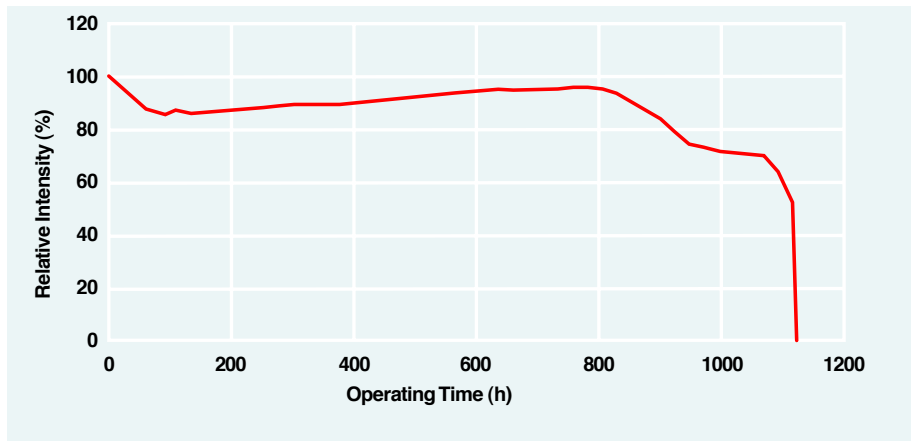

▲ Dimensional Outline of FiberLight.

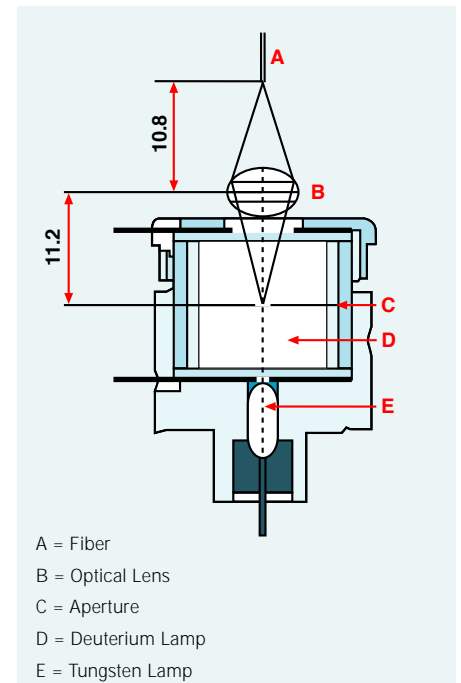

▲ Cross section of the FiberLight lamp module showing: the tungsten lamp, the rf excited Deuterium lamp and the optical system which projects the UV and visible light output into the fiber.

FiberLight with Suprasil window, spectral distribution measured under vacuum with optical fibers of different lengths.

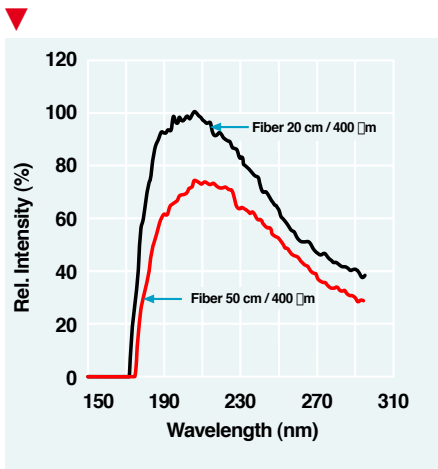

Spatial Intensity Distribution of the Deuterium lamp – measured without lens.

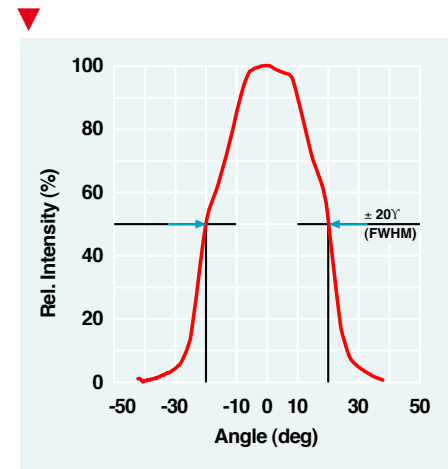



General Specifications	UV-Vis Light Source FiberLight
Spectral Distribution	200 – 1100 nm, Options: 185 – 1100 nm, 160 – 1100 nm
Power Consumption	Approx. 6 Watt (both lamps in operation)
Power Requirements	12 Vdc/0.6 Adc
Ambient Temperature	5 – 35 °C
Relative Humidity	Max. 90 %, non-condensing
Dimensions (LxWxH)	157 x 55 x 37 mm
Shutter	Lamp off/dark current measurement, TTL controlled
Functions	Deuterium and tungsten lamp can be triggered separately by a TTL signal
Light exit	SMA 905 connector for coupling to optical fibers
Optical Fiber	Fiber diameter 200 µm, 400 µm, 600 µm
Numerical aperture	Deuterium Lamp 0.245, Tungsten Lamp 0.057
Cooling	Not required
<b>Deuterium Lamp</b>	<b>US Patent No. 5801.495, US Patent No. 5814 951</b>
Spectral Distribution	200 – 400 nm line free, Option 160 – 400 nm
Window material	Fused silica, Synthetic silica
Light output (radiant intensity)	> 5 x 10 <sup>-8</sup> W/sr @ 240 nm
Stability	< 1 x 10 <sup>-3</sup> AU
Drift	< 0.25 %/h
Exciting frequency	250 kHz
Ignition voltage	Approx. 1 kV
Life	≥1000 h @ 240 nm (50 % intensity loss)
Power consumption	Approx. 3 W
<b>Tungsten Lamp</b>	
Spectral Distribution	400 – 1100 nm
Voltage	5 Vdc
Current	45 mA dc
Life	> 2000 h
<b>Replacement Lamp Module</b>	<b>DTM 6/10</b>
Part No.	45006253

06/06 HNC-B154E



#### Options

	DTM 6/10	DTM 6/50	DTM 6/10S	DTM 6/50S
FiberLight Type	<b>DTM 6/10</b>	<b>DTM 6/50</b>	<b>DTM 6/10S</b>	<b>DTM 6/50S</b>
Part No.	<b>80007444</b>	<b>45006281</b>	<b>80000755</b>	<b>80001017</b>
Aperture size	1.0 mm	0.5 mm	1.0 mm	0.5 mm
Window material	Fused silica	Fused silica	Synthetic silica	Synthetic silica
Spectral distribution with optical fiber	200 – 1100 nm	200 – 1100 nm	185 – 1100 nm	185 – 1100 nm
Spectral distribution at operation under vacuum:				
without optical fiber	185 – 1100 nm	185 – 1100 nm	160 – 1100 nm	160 – 1100 nm
Recommended Fiber Diameter	400 – 600 µm	200 – 600 µm	400 – 600 µm	200 – 600 µm
Replacement Lamp Module	<b>DTM 6/10</b>	<b>DTM 6/50</b>	<b>DTM 6/10S</b>	<b>DTM 6/50S</b>
Part No.	<b>45006253</b>	<b>45006266</b>	<b>80000756</b>	<b>80001018</b>

#### Germany

##### Heraeus Noblelight GmbH

Heraeusstraße 12-14

63450 Hanau

Telephone +49 6181/35 5085

Fax + 49 6181/35 7970

hng-analyticalcallamps@heraeus.com

www.heraeus-noblelight.com

#### U.S.A.

##### Heraeus Noblelight LLC

2150 Northmont Parkway Suite L

Duluth, GA 30096

Telephone +1 770 418 0707

Fax +1 770 418 0688

analytics-usa@heraeus.com

www.heraeus-noblelight.com

#### United Kingdom

##### Heraeus Noblelight Analytics Ltd.

Nuffield Close

Cambridge CB4 1SS

Telephone +44 1223 424100

Fax +44 1223 426338

hna-analytics@heraeus.com

www.heraeus-noblelight.com

#### Distributor

msscscientific Chromatographie-Handel GmbH

Gneisenaustrasse 66/67

10961 Berlin - Germany

Telephone +49 30 6270 6087

Fax +49 30 6270 6089

info@msscscientific.de

www.msscscientific.de